

M401-01 – RS422 – Frequency Generator and Meter

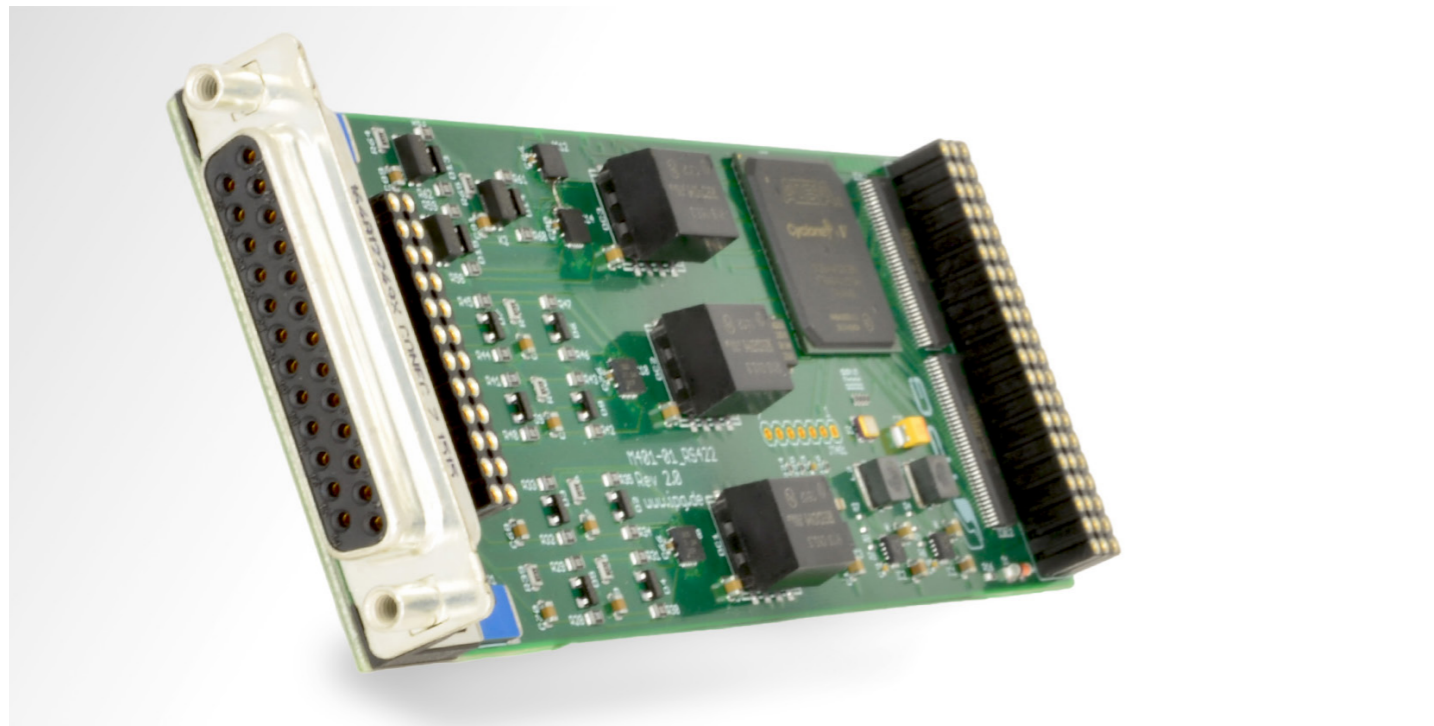

General Features

- 2 explicit RS422 input units with 4 input channels
- One unit configurable to be either input or output with 3 input or output channels
- Input and output levels RS422 compliant
- Galvanic isolation of each unit against each other and against system supply
- Jitter (peak to peak): 10ns

Signal Input Features

- The inputs of each unit can be configured as
 - Independent frequency meters
 - Quadrature decoder with signal „A“, „B“ and „REF“ and an additional independent frequency meter (Unit 2 has no 4th input channel)
 - Binary inputs
- 32bit signal edge counter
- Measuring principle: For each edge a time stamp is stored within a circular buffer
- Immediate detection of missing pulses and rapid slowing down of the frequency
- Quadrature decoding offers measuring of the following quantities
- Absolute angle
 - Referenced angle measuring with zero-point detection
 - Simultaneous frequency & angle measurement

Signal Output Features

- The output channels of unit 2 can be configured as
 - Independent frequency generators
 - Quadrature encoder with signal „A“, „B“ and „REF“
 - Binary outputs
- Continuous frequency range from 0 up to 25MHz.
- Accuracy and range of values meets 40bits
- 2 frequency update modes:
 - Immediate frequency change within the current period by integrating the angular velocity
 - New frequency values get active at the beginning of the next period
- 3 pulse width modes:
 - Fixed high duration (independent from the period time)
 - Fixed low duration (independent from the period time)
 - Pulse width proportional to period time

Use Cases

- Measuring dynamic rotation speeds in dyno test systems
- Acquiring torque sensors outputs in dyno applications

Block Diagram

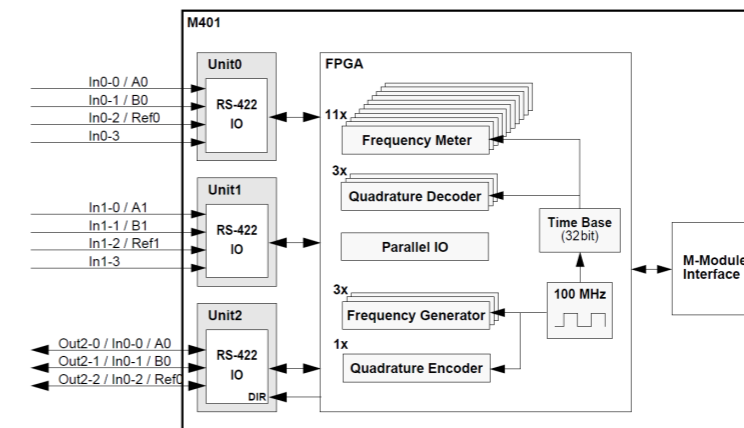

Technical Data

Channels	
Number of channels	2 units with 4 input channels each 1 unit configurable as input or output with 3 channels

Input Channels	
Working voltage range	+/-0.2V <= Vdiff,in <= +/-5V RS422 compliant
Save voltage range	-20V .. 20V
Frequency range	0 .. 2MHz
Sample rate	100MHz
Circular buffer size	512 x 32bit words for each channel
Input modes:	<ul style="list-style-type: none"> • Binary input mode (12 channels) • Frequency meter mode (12 channels) • Quadrature decoder mode (3 channels)

Output Channels	
Output voltage	+/-4V <= Udiff,Out <= +/-5V
Output frequency range	0 .. 25MHz
Frequency resolution	10ns
Pulse width resolution	10ns
Jitter (peak to peak)	10ns
Output modes	<ul style="list-style-type: none"> • Binary output mode (6 channels) • Frequency generator mode (6 channels) • Quadrature encoder mode (3 channels)

General Features	
Address space	A08 and A24
Available connectors	25 Pin SubD connector, female

Order Information

Order Number	IO-M401-01
--------------	------------