

Building Credibility Together

Cross-Company Collaboration for Credible Simulation Standards

Kocsán Lajos, Robert Bosch GmbH

Lingegowda Aurobbindo, Bosch Global SW Pvt Ltd

Trust by Credibility



*Standards &
Collaboration*



Speed



Capabilities



*Simulation &
Virtualization*



*Safety &
Compliance*



Flexibility

Credible simulations need everyone onboard

- OEM
- Supplier
- Tool/Model Vendor

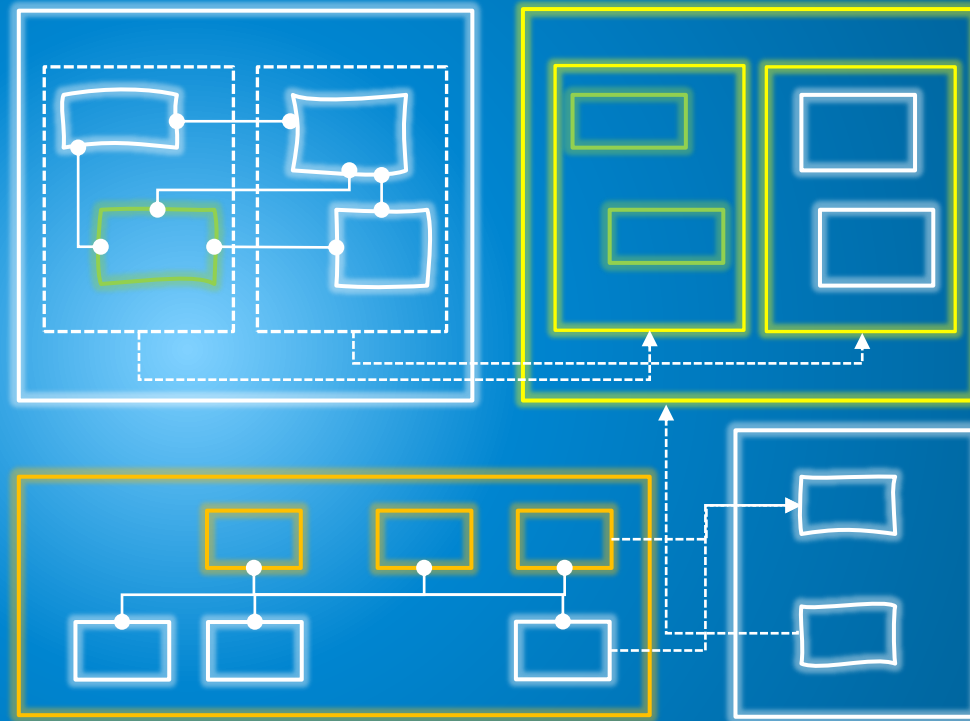

Why do we need Credible Simulation?

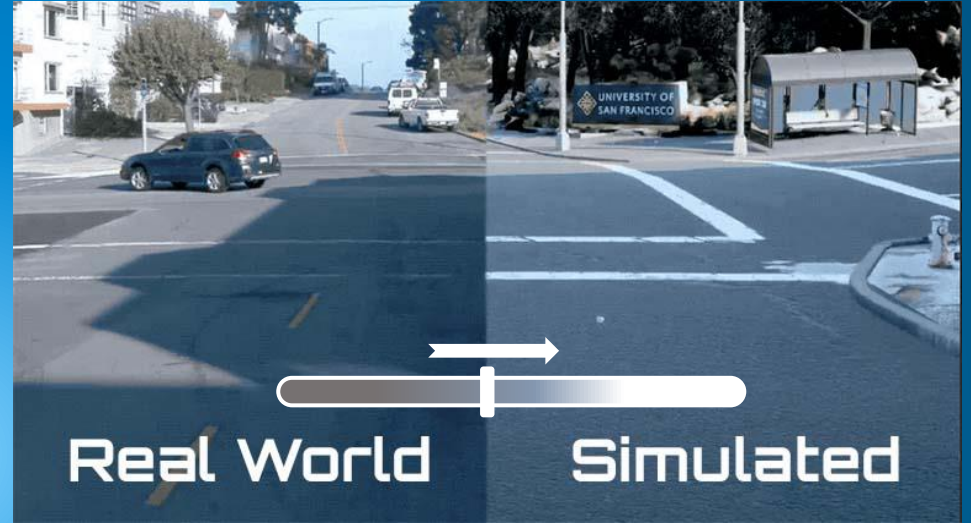

**With credible simulations,
we navigate complex challenges with reliable guidance.**

What is the key ingredient to assessing Credibility?

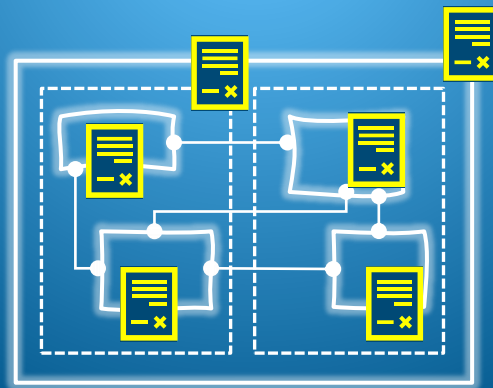
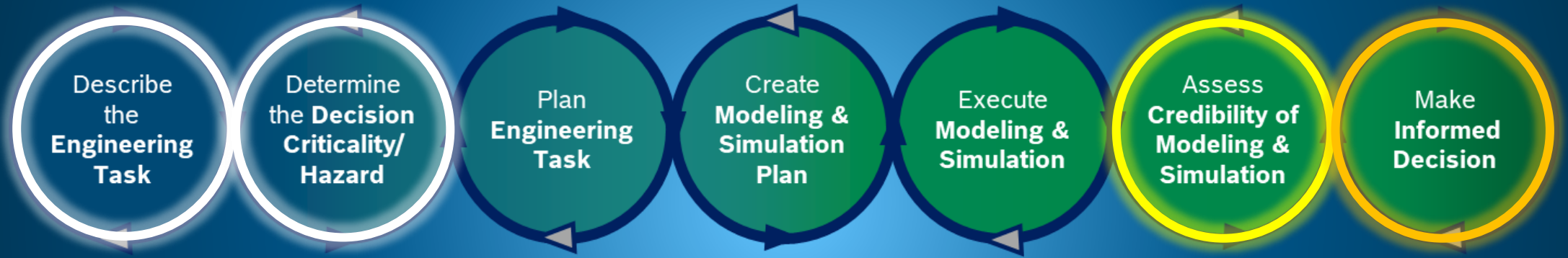

Key ingredient: Information. How do we obtain it?



Standards & Collaboration

Smart Systems Engineering - SmartSE

Building Blocks for cross-company simulation-based engineering

25+ project participants



Mission Phase 5 (2022-2024)

Enabling collaborative development and validation of complex products by simulation along a multi-tier supply chain.

SmartSE Project Organization

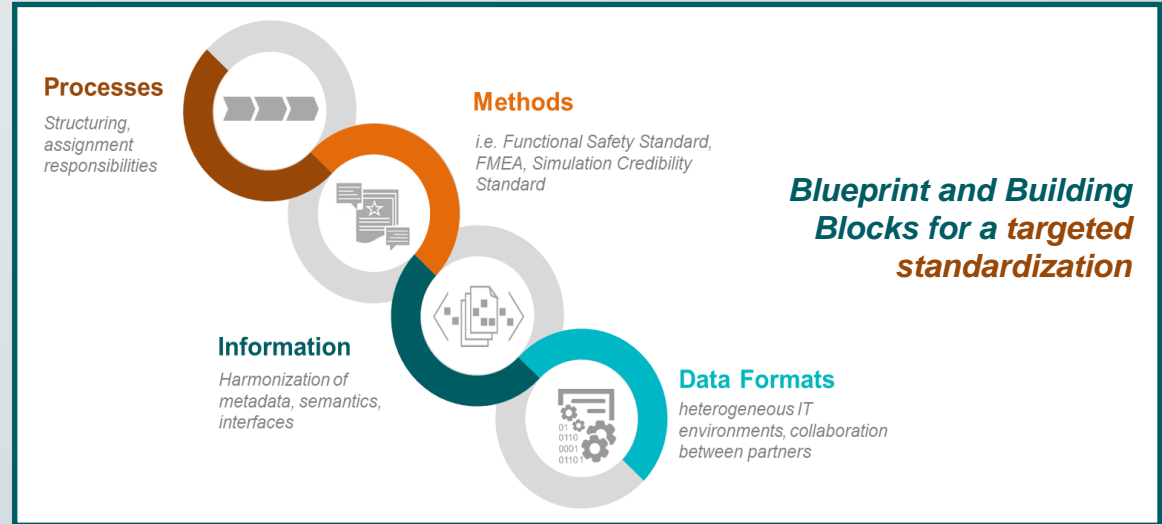
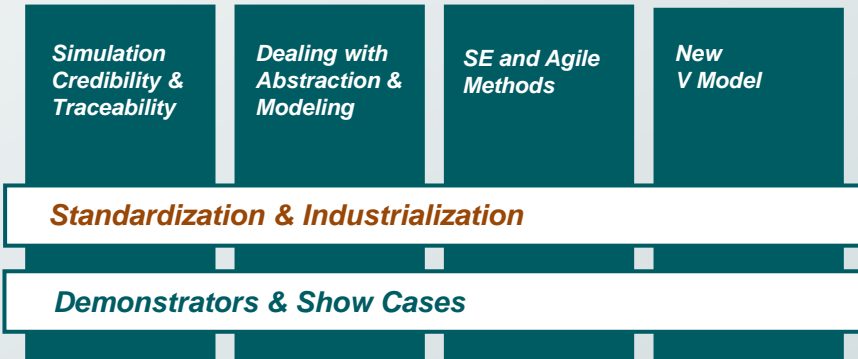

The initiation, development and industrialization of standards in the field of model-based and cross-company development is an important part of the work of the SmartSE project group.

Standardization Landscape for “Simulation-based Collaboration”

Examples for Standards in context Simulations

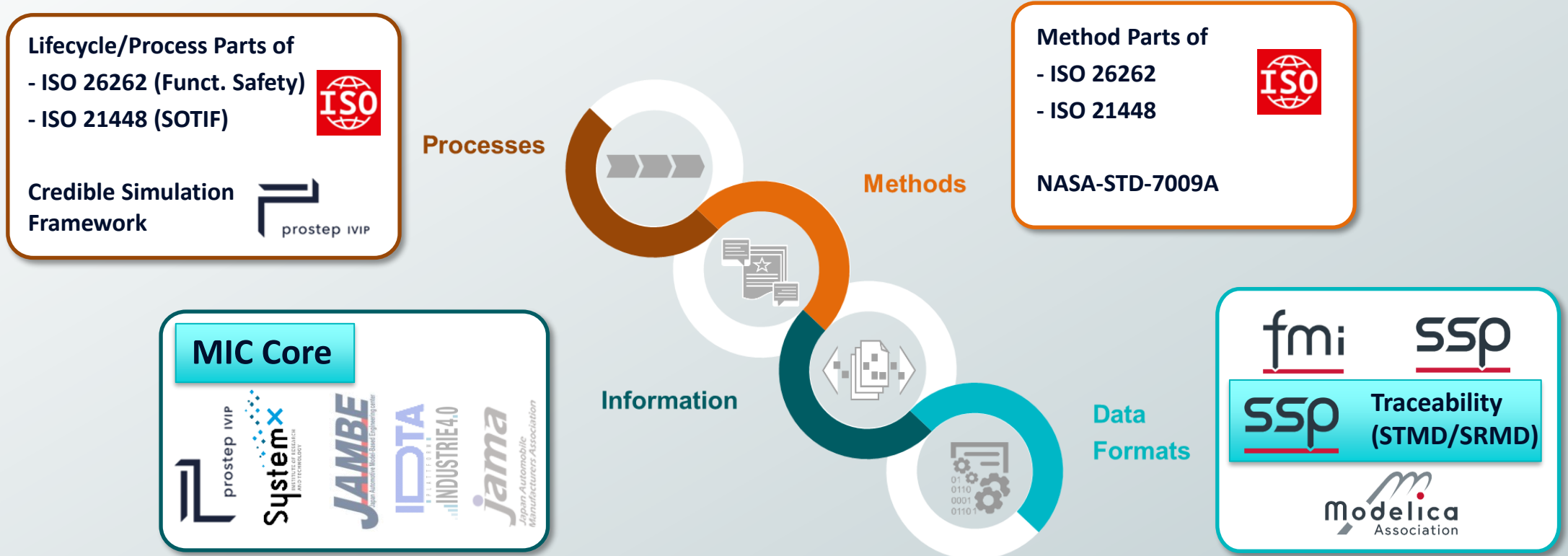

Our focus is on norms and standards relevant for simulations with special **attention to new developments and gaps** as well as the **interaction of the different levels**.

MIC Core Specification

(Model Identity Card)

Administrative Data	Model name	Model identifier	Model description	Release	Release date
	Release type	Model supplier	Model confidentiality level	Legal restriction	
Purpose and Objectives	Model purpose				
Subject Information	Modelled entity				
Implementation	Modeling choice	Model limitations	Model classification	Software and hardware environment requirements	
Verification and validation	Verification status	Validation status	Verification & Validation procedure and criteria	Verification & Validation report	

Practical example for Metadata sharing

Cross domain simulation models and Collaborations

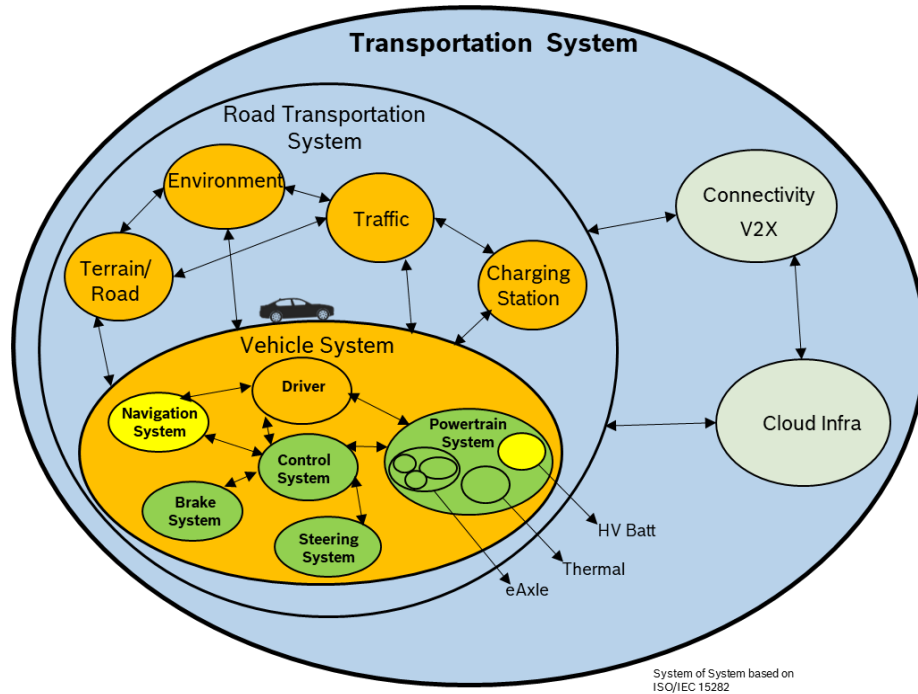

Practical example for Metadata sharing

Powertrain subsystem with Vehicle system: Functional Chain

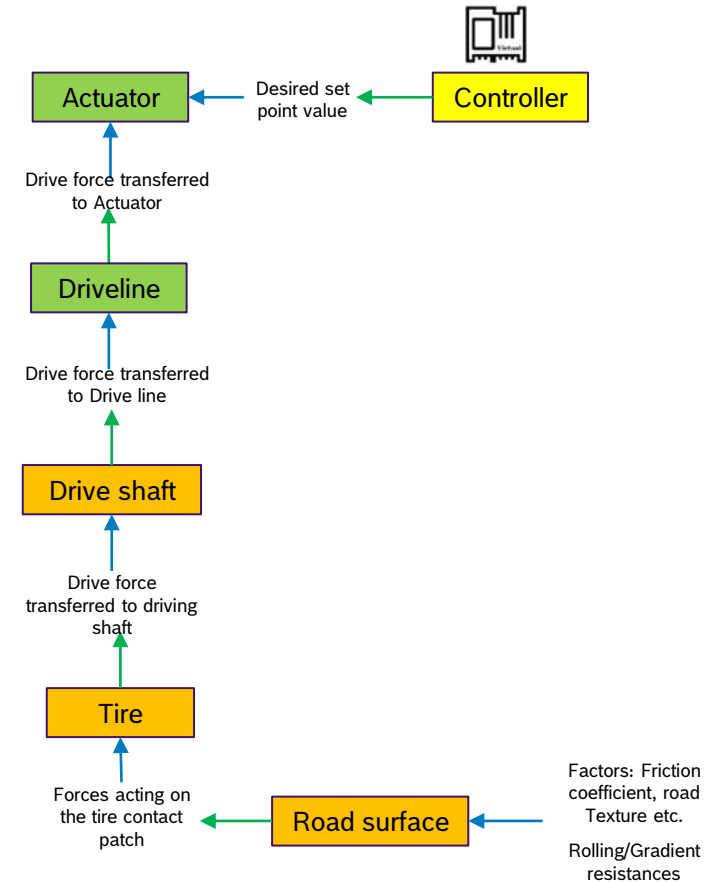
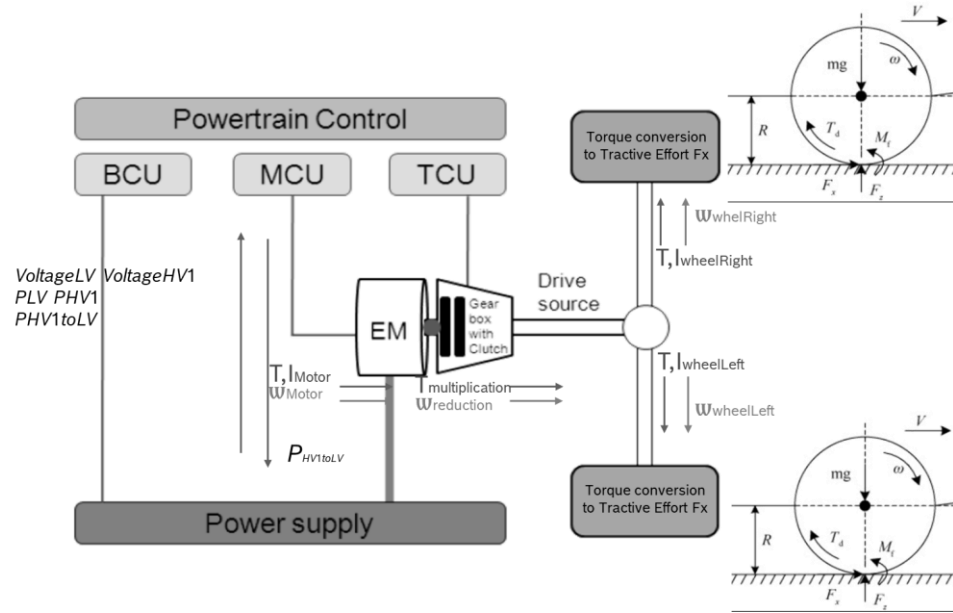
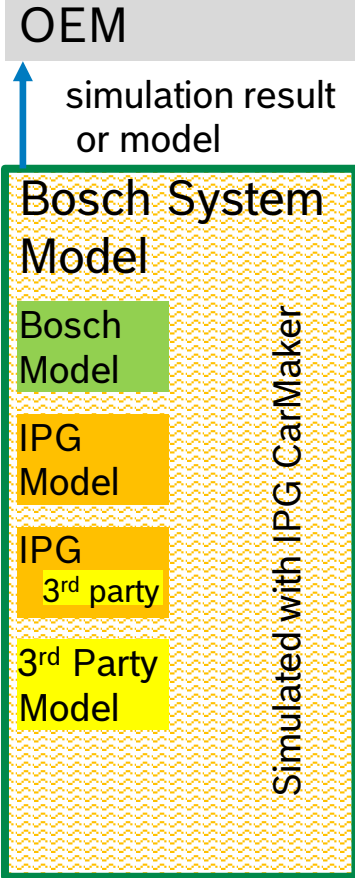

Practical example for Metadata sharing

Multiparty layered composition and communication

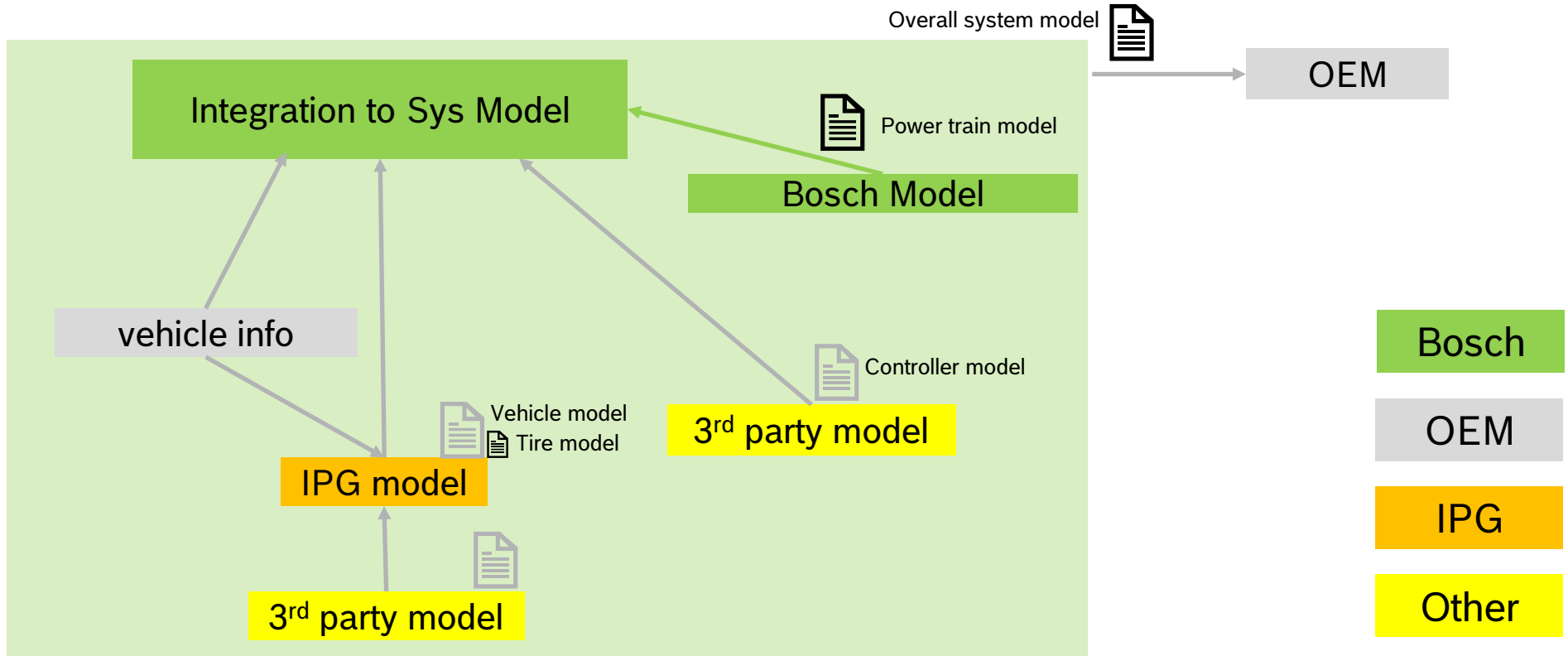

Practical example for Metadata sharing SSP project with shared srmd files

The screenshot displays the 'easySSP' web application interface. The browser address bar shows 'https://www.easy-ssp.com/app/'. The page header includes 'orchideo | easySSP Trace' and a project icon labeled 'CM_Demo_Veh1.ssp'. A central navigation bar shows a process flow: Analyze > Requirements > Design > Implementation > Execution > Evaluation > Fulfillment. The main content area is titled 'Task Resources' and contains a search bar and a list of files: 'CM_Vehicle.srmd', 'eDrive_PTBS.srmd', and 'IPG_MagicFormula61_MIC.srmd'. The 'IPG_MagicFormula61_MIC.srmd' file is selected, and its properties are displayed in a panel on the right. The properties panel shows: 'Kind: Document', 'Master:', 'Description:', and 'Defined in: CM_Demo_Vehicle'. The file's metadata includes 'Mime-Type*: application/x-srmd-meta-data', 'File Size: 23 Bytes', and 'Internal: No'.

Credible simulations need everyone onboard OEM, Supplier, Tool & Model Vendor

Join us in SmartSE!

- Develop common understanding and solutions
- Build credibility together



 
Lajos György Kocsán
Driving Cross-Company Credible Simulation | MBSE
DevOps | SPDM | Software & Simulation Engineer



 
Aurobbindo Lingegowda
Subject Matter Expert- EV Vehicle
System Simulation

